

## DESCRIPTION

The PAV5000 measures air velocity in a robust, probe-style package. Fully calibrated and temperature-compensated, OEMs can easily incorporate the PAV5000 into a portable anemometer or a fixed in-duct air velocity monitor.

The PAV5000 features Posifa's third-generation thermal flow die, benefiting from the latest innovations in microfabrication. The sensor die uses a pair of thermopiles to detect changes in temperature gradient caused by mass flow, delivering excellent signal-to-noise and repeatability. The "solid state" thermal isolation structure on the sensor die eliminates the need for the surface cavity or fragile membrane used in competing technologies, making the sensor resistant to clogging and pressure shock.

As compared to the traditional thermistor-based anemometer sensor, which connects to the circuit via a thin thread, the PAV5000's sensing element consists of a solid silicon chip flush-mounted onto a printed circuit board. The PAV5000 is especially robust against damage caused by vibration, dropping, or collision.

The PAV5000 provides an I<sup>2</sup>C digital output via a connector-terminated wire harness, and features an on-board digital temperature sensor that is accessed via the same I<sup>2</sup>C bus.

## APPLICATIONS

- Portable anemometers
- Fixed in-duct air flow monitors



## FEATURES

- Unsurpassed performance in a robust and cost-effective package
- "Solid state" sensing core (no surface cavity or fragile membrane) is resistant to clogging, pressure shock, and vibration
- No moving parts
- Fast response times ( 20 ms typ)
- Excellent repeatability (1 % FS)
- On-board digital temperature sensor
- Robust, probe-type package

## MAXIMUM RATINGS

- Operating temperature: -25 °C to 65 °C
- Storage temperature: -40 °C to 90 °C
- Humidity: 0 to 100 % RH, non-condensing

## SPECIFICATIONS

Test Conditions: Vin=5 VDC, Ta=25 °C. Relative Humidity: 40 % < RH < 60 %					
SPECIFICATIONS	MIN	TYP	MAX	UNIT	CONDITIONS
Range	0		30	m/s	
Output	5,000 to 35,000			Count	
Resolution		0.001		m/s	
Repeatability		1 %		F	
Accuracy		5 %		F	
Response Time		20		ms	
Supply Voltage	4.8		5.5	VDC	
Supply Current		21		mA	at 5 V supply
Temperature Sensor Range	-55		125	°C	
Temperature Sensor Resolution		0.0625		°C	
Temperature Sensor Accuracy		1		°C	From -20 °C to 65 °C

## OUTPUT DESCRIPTION

---

### Calculating Wind Speed From Digital Output

To access wind speed output, please refer to the "[PAV Series I<sup>2</sup>C Application Note](#)". Please note the I<sup>2</sup>C address of 0x50.

Wind speed (m/s) = (output count - 5,000) / 1,000

For example, when output reads 18,000, the wind speed is 13 m/s.

### Digital Temperature Sensor Output

The PAV5000 has a digital temperature sensor from Novosense, which shares the same I<sup>2</sup>C bus but at a different I<sup>2</sup>C address of 0x48. To read from the NST117, please refer to its data sheet.

## PACKAGE DIMENSIONS

### PAV5000

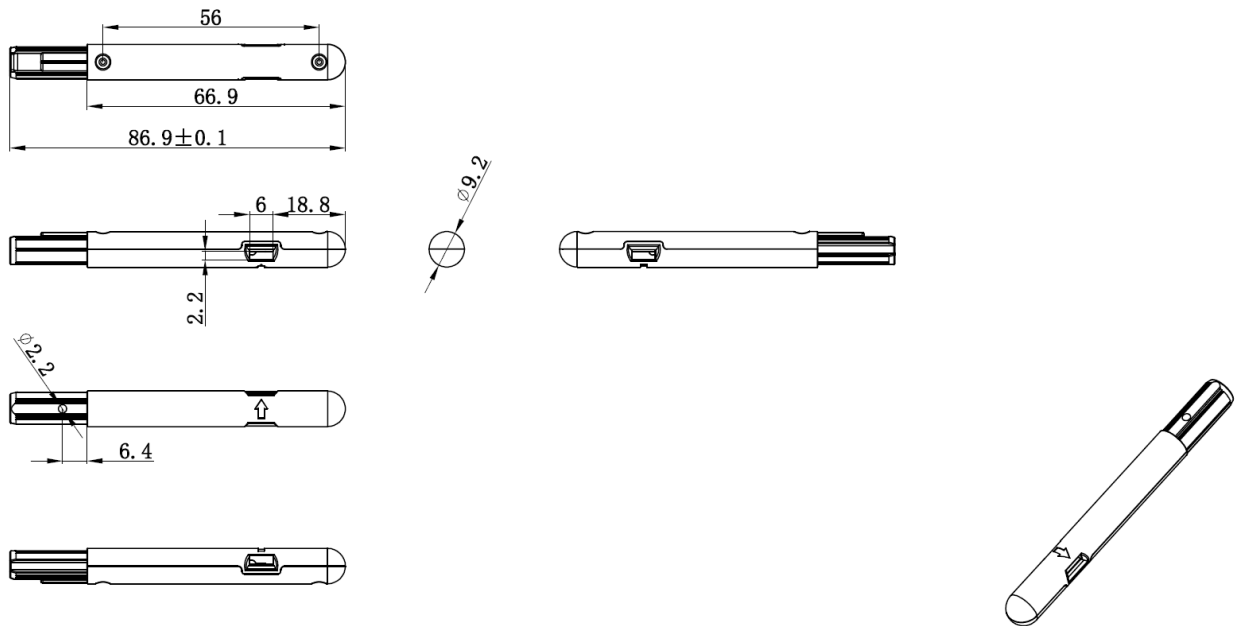

Pad/Wire#	Description (Wire Color)
1	Vdd (Red)
2	GND (Blue)
3	SDA (Yellow)
4	SCL (Green)

## ORDERING INFORMATION

PART NUMBER	SPECIFICATIONS
PAV5020	20 m/s, digital I <sup>2</sup> C output, linear, probe only
PAV5030	30 m/s, digital I <sup>2</sup> C output, linear, probe only
PAV5040	40 m/s, digital I <sup>2</sup> C output, linear, probe only

## CUSTOMIZATION OPTIONS

For OEM customers, we provide custom extensions, such as attaching the anemometer probe to a custom telescopic rod (see PAV5100 datasheet). To discuss further options please reach out to our sales team.