

PGS6454-R Refrigerant Sensor

USER MANUAL



Copyright notice

©2024 Posifa Technologies, Inc. All rights reserved.

Trademark credit

Posifa and the Posifa logo are trademarks of Posifa Technologies, Inc.

Disclaimer

The content of this manual may change from time to time without notice. We accept no liability for any errors that may appear in this manual nor do we make any expressed or implied warranties regarding the content. As far as practical, we have ensured that the products have been designed and constructed to be safe and without risk when properly installed and used in accordance with their operating instructions.

We accept no liability for loss of profit, loss of market, or any other indirect or consequential loss whatsoever.

Product warranty and limit of liability are dealt with in our standard terms and conditions of sale, or negotiated contract under which this document is supplied.

You must use this product as described in this manual. Read the manual before you install, operate, or maintain the product.

Table of Contents

Copyright notice	3
Trademark credit	3
Disclaimer	3
1. Safety and compliance	5
1.1 <i>Definition of warnings and cautions</i>	<i>5</i>
2. Introduction	6
2.1 <i>Description</i>	<i>6</i>
3. Technical data	7
3.1 <i>Operating and storage conditions</i>	<i>7</i>
3.2 <i>Performance data</i>	<i>7</i>
3.3 <i>Mechanical data</i>	<i>8</i>
3.4 <i>Electrical interface</i>	<i>8</i>
3.5 <i>Connector spec</i>	<i>9</i>
4. Installation	9
5. Communication protocol	10
5.1 <i>Interface setting</i>	<i>10</i>
5.2 <i>Frame definition</i>	<i>10</i>
5.3 <i>Register description</i>	<i>12</i>
6. Disposal	14

1. Safety and compliance

1.1 Definition of warnings and cautions



NOTICE:

For safe operation from the start, read these instructions carefully before you install or commission the equipment, and keep them safe for future use.

Read all the safety instructions in this section and the rest of this manual carefully, and make sure that you obey these instructions. The equipment must only be operated and maintained by trained personnel in the proper condition and as described in this instruction manual.

Obey local and state requirements and regulations. If you have any questions about safety, operation, or maintenance of the device, please contact our nearest subsidiary.

Important safety information is highlighted as warning and caution instructions. Obey these instructions.



WARNING:

If you do not obey a warning, there is a risk of injury or death. Different symbols are used according to the type of hazard.



CAUTION:

If you do not obey a caution, there is a risk of minor injury and damage to equipment, related equipment, and processes.



NOTICE:

Information about properties or instructions for an action which, if ignored, will cause damage to the equipment.

We reserve the right to change the design and the stated data. The illustrations are not binding.

Keep the instructions for future use.

2. Introduction

2.1 Description

The PGS6454-R, refrigerant sensor measures R454B refrigerant concentration in the air by measuring the change in thermal conductivity of the gas mixture.

R454B refrigerant and air have different thermal conductivity. A variation in refrigerant concentration results in changes in the thermal conductivity of the gas mixture. As compared to competing detection technologies, thermal-conductivity-based detection offers the benefits of superior long-term reliability (there's no lamp or delicate optical path to break, and it's not reactive to chemical contaminants) and resilience in harsh operating environments.

The PGS6454-R, refrigerant sensor uses Posifa's second-generation MEMS thermal conductivity sensing element. It features a patented "heat transfer cavity" that achieves highly sensitive and repeatable thermal conductivity measurement by eliminating possible occurrences of natural convection inside the cavity. Because thermal conductivity measurement is accomplished completely inside the sensor chip, maximum miniaturization can be realized at the device level. Compact leak detectors are critical for HVAC equipment manufacturers that have to retrofit detectors into existing designs.

To account for changes in thermal conductivity due to humidity and barometric pressure variations, the PGS6454-R refrigerant sensor incorporates a relative humidity sensor and a barometric pressure sensor for compensation.

The output from the PGS6454-R refrigerant sensor is RS485 Modbus RTU.

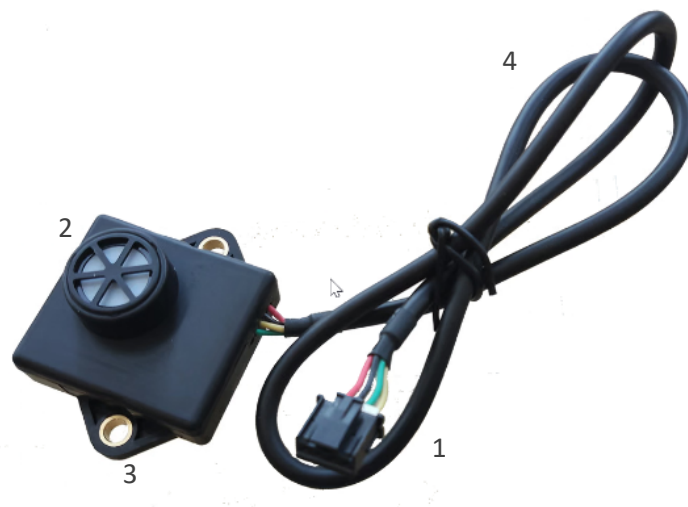

- | | |
|-------------------------|------------------|
| 1. Electrical connector | 2. Vent membrane |
| 3. Electronics housing | 4. Cable |

Figure 1: General view

3. Technical data

3.1 Operating and storage conditions

ELECTRICAL/ENVIRONMENTAL					
SPECIFICATIONS	MIN.	TYP.	MAX.	UNIT	CONDITIONS
Supply voltage	3.3	5	5.5	Vdc	
Operating current - peak			22	mA	When sensor heater is turned on
Operating temperature	-40		85	° C	
Storage temperature	-40		90	° C	
Operating relative humidity	0		100	% RH	Max. 40 °C dew point
Operating pressure	70		120	kPa	

Table 1: Operating and storage conditions

3.2 Performance data

PERFORMANCE					
SPECIFICATIONS	MIN.	TYP.	MAX.	UNIT	CONDITIONS
Target gases	R454B (others available upon request)				
Measurement range	1		100	% LFL	
Warm-up time			1	s	
Response time			1.5	s	Default, configurable
Accuracy		± 2.5		% LFL	
Alarm setpoint		10		% LFL	Default, configurable
Communication	RS485 Modbus RTU				

Table 2: Performance Data

3.3 Mechanical data

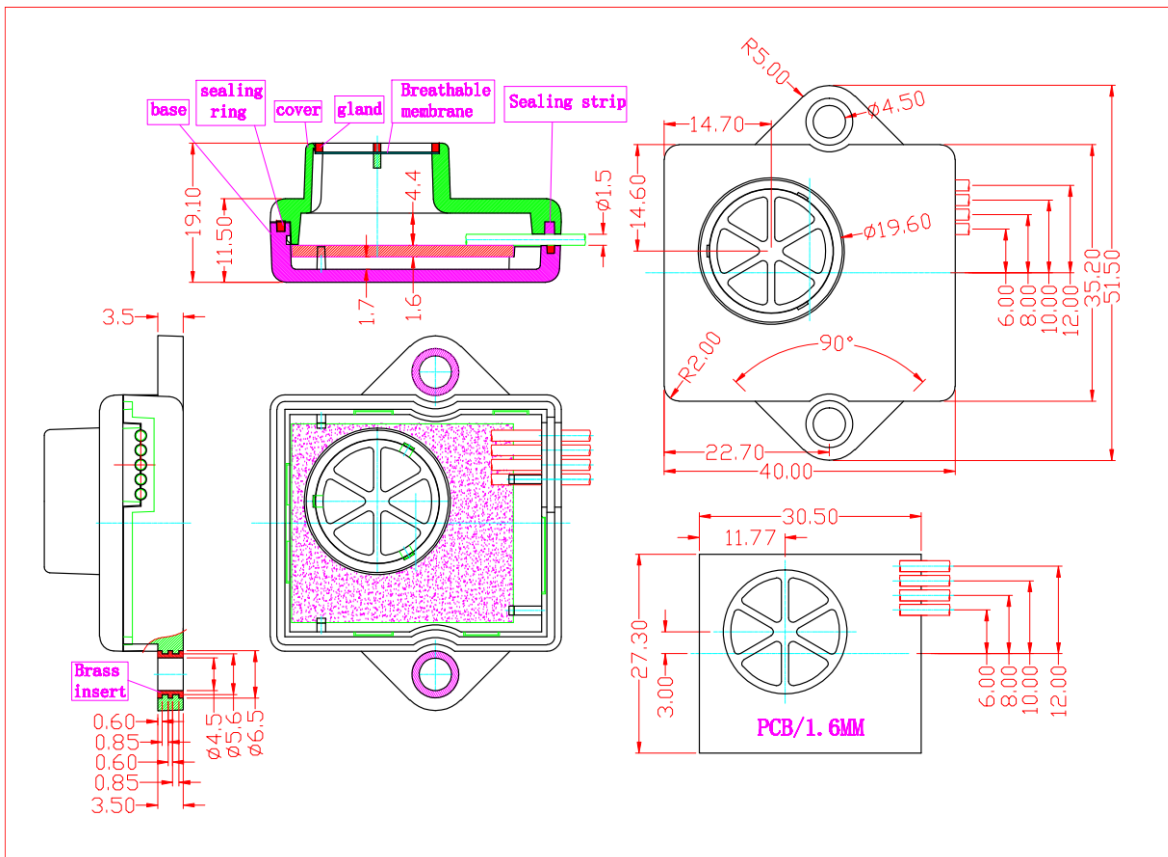

Figure 2: Dimensions (mm)

3.4 Electrical interface

PIN	Description	Color
1	+5 Vdc	Red
2	Ground	Black
3	B-	Blue
4	A+	Yellow

Table 3: PIN definition

3.5 Connector spec

Figure 3: Connector dimensions (mm)

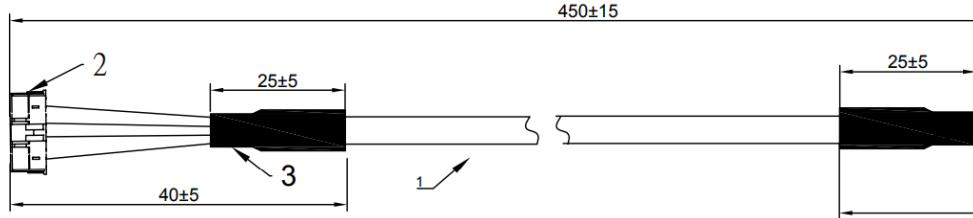

4 wires are 22 AWG, comply with the UL1007 standard
Whole cable complies with the UL2464 standard
Connector model: XHD-4YB; brand: JST

Figure 3: Connector dimensions (mm)

4. Installation

The PGS6454-R refrigerant sensor must be exposed to measured air at all times. The location must be chosen so as to maximize air exchange; dead spaces must be avoided. Preferably, the vent in the module should be facing downward. If this is not possible, it should be vertical. It should never be facing upward, to prevent accumulation of dirt and water.

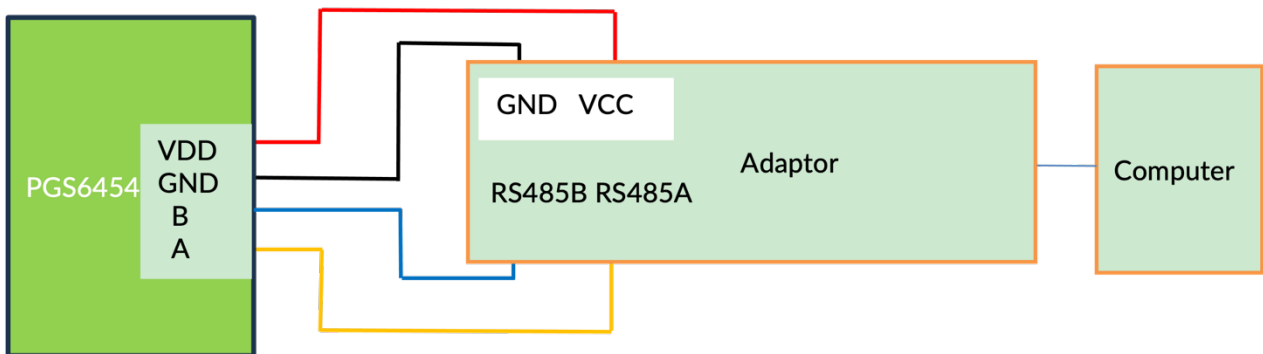

Figure 4: Connection wiring

5. Communication protocol

5.1 Interface setting

- a) Initial baud rate is 2400 bps
- b) 1 start bit, 8 data bits, 2 stop bits, and no parity
- c) Master/slave asynchronous communication, half-duplex mode
- d) End-of-frame definition: If the received data exceeds a 1.5-character interval without receiving the next byte, it is considered that the data reception is finished this time

5.2 Frame definition

5.2.1 Definition of the normal communication frame

Data length n is 0-251

Address (1 byte)	Function code (1 byte)	Data (n bytes)	CRC (2 bytes)
---------------------	------------------------------	-------------------	------------------

5.2.2 Address

- ① When the master sends, the address sent is the target slave address, which is used to instruct the receiver. When all the slaves are required to receive and process the message, it sends its own address 0x00, and all the slaves respond but do not return an answer. Otherwise, it sends a single slave address, which instructs the slave to process the message.
- ② When the slave sends, the address sent is its own address, which is used to instruct the answering party.

5.2.3. Function code

Function code	Name	Function	Normal answer function code	Abnormal answer function code
0x03	Read multiple registers	Read registers	0x03	Function code+0x80
0x06	Write single register	Write single register	0x06	
0x10	Write multiple holding registers	Write multiple holding registers	0x10	

Data composition when the function code is an abnormal answer function code:

Slave ID	Function code (0x90)	Exception code	Crc-16	
		01 or 02 or 03 or 04	LSB	MSB
1 Byte	1 Byte	1 Byte	1 Byte	1 Byte

Explanation of terms:

- ① Register address: the starting position of the register to be operated in the table, occupied as 1 word
- ② Register quantity: the number of registers to be operated, occupied as 1 word
- ③ Bytes quantity: the length of the content of the register to be operated, the unit is 1 Byte, 0x00 for no content
- ④ Data content: the content of all registers corresponding to the operation to be performed
- ⑤ Exception code: indicates the reason for the exception, see the description in the Exception Code section for details

5.2.5 CRC checksum

The CRC checksum is 16-bit, calculated by the sending device. The calculation uses polynomial 0xA001, with an initial value of 0xFFFF. The calculation starts from the address code. Only the data bits are calculated, not the start bit, stop bit, or check bit. The receiving device recalculates the CRC value after receiving the message, and compares the calculation result with the received CRC value. If the two values are not equal, it is invalid data.

When the CRC is added to the message, the low byte is added first, then the high byte.

5.3 Register description

Access	Name	Register address	Number of registers	Type	Description
R	Register specification version	0x0100	1	[uint8,uint8]	Version of the protocol specification; high byte is major, low byte is minor number
W	Device reset	0x0101	1	bool	The sensor is reset if a "1" is written to this register Range: 0-1

Data query

R	Operating mode	0x0110	1	enum	The operating mode of the device; there are no measurements available during startup 0: Startup 1: Measuring
R	Leak signal	0x0111	1	bool	A flag that turns on when the concentration exceeds the alarm threshold. By default, the leak signal is sustained for 5 minutes after the concentration is again below the leak signal threshold 0: No leak detected 1: Active leak detection or sustained period after leak detection
R	Errors	0x0112	1	uint16	See error table
R	Gas concentration LFL	0x0113	1	int16	The last measured gas concentration in %LFL, multiplied by 10 (example: 251 for 25.1 %LFL) Resolution: 0.1 %LFL Range: 0 %LFL - 100 %LFL (clamped)
R	Sensor temperature	0x0114	1	int16	The last measured sensor temperature in °C, multiplied by 10 (example: 210 for 21 °C) Resolution: 0.1 °C Range: -45 °C - +130 °C
R	Sensor humidity	0x0115	1	int16	The last measured sensor humidity in %RH, multiplied by 10 (example: 305 for 30.5 %RH) Resolution: 0.1 %RH Range: -6 %RH – 119 %RH

Settings

R/W	Device address	0x0120	1	uint8	Slave address of the Modbus interface Range: 1-247 (as per Modbus specification) Default: 1 A soft reset or power cycle is required to apply a change of this value
	Leak signal threshold	0x0124	1	uint16	The gas concentration level that triggers the leak signal Resolution: 0.1 %LFL (example: 251 for 25.1 %LFL)

Device info

R	Device marking	0x0140	10	String[20]	Reads the device marking. To be set, no default. Represented as 0-paddedstring without 0-termination
R	Firmware version	0x014A	1	uint8[2]	Firmware version Format: High byte: major version Low byte: minor version
R	Gas type	0x014C	1	enum	The gas type the sensor is configured for. 0: R32 1: R454B
R	Lifetime counter	0x14E	1	uint16	The device's elapsed lifetime Resolution: 1 day (example: 365 for 1 year) Range: 0 days - 65535 days (-179 years)

Bit index	Error	Description
0	internal error	Errors that result in untrustworthy measurement data. For example,internal communication errors
1	Value out of limit	The sensor detects is out of the specified T, RH, and concentration limits
3	Self-check failed	Errors resulting from internal check on proper operations, invalid settings, etc.
4	Dead	Any sensor error that is unrecoverable and requires sensor replacement
5	Over lifetime limit	The lifetime limit is reached (might be irrelevant in new UL editions)

Table 4: Register definition

6. Disposal

- Dispose of the sensor, components, and accessories safely as per all local and national safety and environmental requirements
- You can recycle the sensor and cables. Contact us or the supplier for more information